

Providing a forecasting model and optimization of the cash balance of bank branches and ATMs with the approach of social responsibilities

Majid Zeinalkhani^a, Nasim Ghanbar Tehrani^{a,*}, Seyed Hamid Reza Pasandideh^a, Mir Mohsen Pedram^b

^aDepartment of Industrial Engineering, Faculty of Engineering, Kharazmi University, Tehran, Iran

^bDepartment of Electrical and Computer Engineering, Faculty of Engineering, Kharazmi University, Tehran, Iran

(Communicated by Seyed Hossein Siadati)

Abstract

Providing cash reserves and providing cash services is one of the main missions of banks, and optimal management of cash to meet the needs of customers while complying with social responsibilities is one of the important challenges in the banking industry. In order to provide a solution, in the current research, we have presented a two-objective mathematical model with a combined approach of cost minimization and action maximization to the social responsibilities of the sample branches of a commercial bank in cash logistics. In order to get better results, first, withdrawal and receipt of customers' cash were predicted using the SARIMAX statistical method and LSTM recurrent neural network, and by comparing the results, the LSTM method was chosen as the superior method with an acceptable level of accuracy. Then, by placing the predicted values in the optimization model, the optimal values of the inventory variables and the amount and time of cash movement of the branches were determined in the cash logistics, which resulted in a significant reduction of the bank's costs in providing cash services and accountability. Complete with the demand for cash from customers, the social responsibilities of the bank were optimized in the cash transfer mission.

Keywords: time series, recurrent neural network, bank branches, cash balance optimization, social responsibilities
2020 MSC: 62M10, 37N40, 68T07

1 Introduction

Providing cash services in each country is the responsibility of its banking network, and banks, including commercial and specialized banks, provide deposit-based services, one of which is cash withdrawal/receipt, in addition to providing credit services. Providing these services is expensive for banks, and among these costs, we can mention the unprofitability of money circulating in the internal network of banks and the costs of transportation, insurance and cash storage [9]. Maintaining cash reserves to meet customers' cash needs is done through liquidity management, monetary control, and sometimes through prudent decisions [6]. Considering that providing services at an optimal level is one of the factors in attracting and retaining customers, banks should consider the appropriate balance between

*Corresponding author

Email addresses: zeynali.majid63@gmail.com (Majid Zeinalkhani), nasim.tehrani@khu.ac.ir (Nasim Ghanbar Tehrani), shr_pasandideh@khu.ac.ir (Seyed Hamid Reza Pasandideh), pedram@khu.ac.ir (Mir Mohsen Pedram)

the costs and the service level of their services, and the amount of cash needed to meet the needs of customers in the branches and cash registers. Maintain ATMs. This is done in most banks, including the bank under review, based on the experience of the bank's branch and treasury staff and with much more maintenance than the actual need. It is worth mentioning that in recent years, statistical methods and commercial software have been used in some of the world's banks and cash transportation companies to better forecast the cash needs of branches and tellers. The amount of surplus cash kept in the bank network has decreased [7, 4]. However, with the development of artificial intelligence and the emergence of new topics and algorithms, including deep learning, it has become possible to improve forecasting methods and reduce logistics costs for banks [1]. Managing the costs related to the provision of cash services is not the only goal of banks in providing services to customers. Compliance with environmental issues and social responsibilities is also an effective factor in the performance of banks, which not only has positive social effects. It has an environmental impact on society, but it also leads to the improvement of the performance of banks in financial indicators [23] For this reason, the fulfilment of social responsibilities, along with reducing the costs of providing and providing cash services, should be paid attention to by the top managers of banks. In order to realize these two goals at the same time, the use of mathematical planning in compliance with legal restrictions, the movement and maintenance of cash, etc. and the use of predictive models with high accuracy complements the optimization part for cash logistics operational planning [16]. In this research, both the processes of predicting and optimizing the cash needed by two bank branches, in one of which the demand for customer cash withdrawal is more than the cash deposit and in the other it is the opposite, along with ATMs/self-receipts allocated to them, we will deal with them using scientific methods, and in the following, we will review the researches done regarding the prediction and optimization of cash, in the third part, the process of providing cash services to customers will be explained. In the fourth part, the steps and how to forecast the cash of the branch and related ATMs are presented, in the fifth part, we will discuss how to optimize the cash balance by considering the costs and social responsibilities of the bank in this regard, and in the sixth part, the results We will examine and analyze the prediction and optimization section, and the research summary will be presented in the last section.

2 Research background

Forecasting and optimization of the cash balance of bank branches and ATMs can be investigated as an integrated process, but in most of the research conducted, researchers separately and in one of the cases of accurate forecasting using statistical methods and artificial intelligence. or optimization of the balance based on the approximate estimation of the required cash, and a small part of the researchers have investigated the forecast with high accuracy and the optimization of the balance of the cash. Also, the implementation of social responsibilities in banks in the process of cash logistics has rarely been considered, and the few cases that have been done have been related to recent years and only to optimization regarding environmental issues [18, 20]. The main research carried out in both sections is as follows: In the forecast section in 2013, Henrik Gurgul et al. [7] modelled and predicted the amount of cash needed by selected ATMs in parts of Europe based on statistical methods that examined and analyzed four years of data. And the comparison of the results indicated the superiority of the seasonal ARIMA method. In 2015, Sharsono et al. [21] using statistical regression methods and ARIMA and ARIMAX methods predicted the number of foreign currency inflows and outflows from the branches of the Central Bank of Indonesia in four regions, during which the ARIMA and ARIMAX methods had a significant advantage in It was compared with the regression method in the prediction tables. In 2019, Weytjens et al. [25] analyzed the three-year cash flow data to predict the cash flow of companies using the classical ARIMA and PROFIT methods and MLP and LSTM artificial intelligence methods and compared the results. that the LSTM method provided more suitable results from the perspective of prediction error measurement indicators. In the same year, Yu Liu et al. [15] presented a deep learning model based on LSTM network in order to optimally allocate cash reserves to bank branches and compared the results with the statistical method of ARIMA, which showed the best performance was the method based on LSTM network. In 2021, Gorodetskaya et al. [5] described a systematic approach to build a machine learning predictive model to solve optimization problems in the banking sector. The proposed model is based on the decision tree algorithm, which after evaluating the results with the index MAPE referred to this approach as a global scenario for various non-stationary time series. In 2022, Jariyavajee et al. [11] have presented a strategy for maintaining cash required by bank branches using deep learning methods, the main objective of which is to determine the level of cash required by the bank branch using historical data instead of It was the experience of branch managers. The results showed a ten percent reduction in the amount of cash required to meet the needs of customers. Also, the logistics costs of providing cash, such as insurance and transportation, were also reduced. In the same year, Fallahtafti et al. [3] used three years of historical data related to three ATMs to predict the amount of cash required by the machines using multiple statistical methods and machine learning in the time before the Corona pandemic. They discussed that the results indicated the superiority of statistical methods in predicting

cash at the time of external shocks. In the optimization-forecasting section in 2015, Zhu et al. [26] presented a single-objective optimization model to reduce cash balance costs of regional branches in a commercial bank, which they solved by using the hue algorithm. and reduced the minimum cash holding limit for branches. In the same year, Van Anholt et al. [22] introduced, modeled and solved a multi-stage model of the routing problem-cash balance of ATMs in the Netherlands and based on historical data and using clustering technique, They performed the analysis of cash and after solving the problem with the branch and bound method, they presented a significant reduction in the amount of cash used in the bank network as an achievement of the research. In 2016, García and Lobillo [4] used business software to predict the cash needed and then provide an algorithm to adjust the cash of bank branches so that the branches do not face cash shortages and surpluses, and the results The research indicated the acceptable performance of the proposed algorithm. In 2017, George Lopez et al [16] improved cash logistics performance of branches in two stages of forecasting using the SVR machine learning method and optimization using the operations research model, and by examining 4-year data of 8 selected branches, the effect Some of the models used in the prediction and optimization section were displayed. In the same year, Larrain et al [14] presented a hybrid algorithm based on neighborhood search to solve the mixed integer programming problem and based on the location of devices and consumption and money transport scenarios to optimize inventory and routing costs. The logistics of ATMs in Chile, by comparing the results of using the proposed algorithm with the results of using the branch-and-bound method, they confirmed the reduction of the gap and the improvement of the lower range of the required cash compared to the branch-and-bound method. In 2018, Bilir and Doseyen [1] presented an integrated model in predicting and optimizing the cash balance of the network of branches and ATMs of a medium-sized bank in Turkey and by analyzing the two-year cash data of the network of branches and ATMs of the bank using Machine learning methods improved the accuracy and prediction error, which led to the reduction of unused money in the branch network The bank's ATMs have been mentioned. In 2019, Ekinici et al. [2] predicted and optimized the aggregate and combined cash requirements of ATMs using linear regression and clustering in a scenario-oriented manner and compared the prediction results with the previous cash flow method. ATMs have confirmed the reduction of money supply costs. In 2020, Kiani et al. [12] using the aggregated data of the average cash withdrawal of ATM machines and knowing the consumption pattern of customers to predict the amount of money consumption in the total of machines using the autoregression method with exogenous input network. (NARX) and after obtaining appropriate forecasting results, they optimized the required amount of cash using the genetic algorithm, which led to a reduction in the occurrence of cash shortages in ATMs. Most of the researches on the optimization of cash have considered only the financial and cost aspects of the optimization, and a handful of researches on the optimization of the cash balance have taken into account environmental issues and social responsibilities. The following two sentences can be named: In 2020, Nazari et al. [18] presented an integrated location-route and inventory optimization model for ATMs in a part of Tehran and minimized the effects of carbon dioxide pollution by considering the bank's environmental responsibilities in cash logistics. In addition to optimizing business goals and solving the model with the lp-metric method. In 2021, Song et al. [20] designed and simulated a reverse logistics network for the ATM industry, and by designing a dual-objective model, they minimized costs and pollution caused by carbon emissions, which solved the model to the optimal network achieved.

3 The process of providing cash services to customers

ATMs and bank branches are two channels for providing cash services to customers. The cash required by the branches and ATMs is different on different days of the year and currently the employees working in the branches use their experience to estimate the amount of cash needed daily and deliver it to the treasury unit at the specified times. They order and receive it at a certain time on the same day or the next day. Also, the surplus cash of the branches is delivered to the bank's treasury according to the announced limits. The cash in circulation in the network of branches and ATMs of a bank is divided into two categories, one category is worn and old money that cannot be used and presented to customers through the network of branches and ATMs, and the other category is usable money that itself it is divided into two categories as follows:

1. Sorted money that can be used in ATMs and branch counters
2. Unsorted money that can only be used at branch counters and cannot be used at ATMs

The reason for not using unsorted money in ATMs is to maintain the functionality of the ATM machine in counting and delivering money requested by customers from the machine. It should be noted that the money arranged in the treasury or branches is prepared and handed over to the operator of the ATM for depositing money. If the sorted money is not delivered by the treasury to the ATM operators or its amount is lacking, it is possible to sort the unsorted money by spending a short time by the branch bankers and preparing it, and thus most of the available banknotes in branches, it can be used in ATMs.

The process of receiving and paying cash at the level of a branch that has an ATM (ATM and self-receipt) is as described in Figure 1:

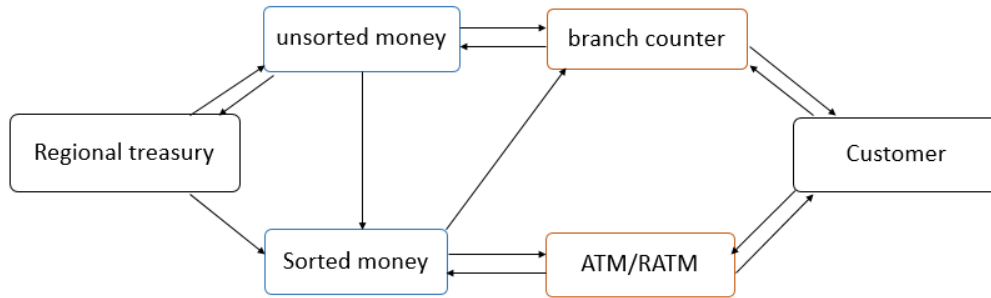

Figure 1: Cash circulation diagram at the level of branches and ATMs

In further explanation, it can be stated that due to the daily cash withdrawal limit for each bank card set by the central bank, usually the high amounts of cash requested by customers are settled and referred by visiting the branch counters. Also, the source of the sorted and unsorted money of the branches is the branch cash register, which is used to exchange cash with the counters and ATMs of the branches, and the amount of sorted money received from the treasury usually corresponds to the required amount of the ATM machine covered by the branches. Be Also, the sorted money in excess of the use of the ATM in the branch counter is delivered to the customers requesting cash.

4 Forecasting the required balance of cash

The prerequisite for optimizing the cash balance of banks is to forecast cash receipts and withdrawals of customers with high accuracy, and to achieve this, both statistical methods and artificial intelligence were used, the steps and details of which are explained in this section.

4.1 Data review and preprocessing

The data used in the research belong to two branches of a commercial bank, both of which have self-receiving machines, in one of them, the amount of cash deposits is more than cash withdrawals, and in the other, cash withdrawals are more. Cash is more than cash deposits that these two branches are assigned to a regional treasury and their liquidity management is done by this treasury unit. It should be noted that the selection of the two branches investigated in the research was done randomly from among the eligible branches, and the data of each branch is divided into two parts of cash receipt and withdrawal data in the daily interval, which represents the total amount of incoming cash. And the output is to the branch and the ATM/self-receiving machine (RATM) of the branch and this data is related to a period of about 5 years from 1395 to 1400. By examining the primary data, we come across three columns: date, cash deposit amount, and cash withdrawal amount, which is in the form of a time series, and in the data section related to cash withdrawals in a very small number of days due to the lack of cash and or device failure, Zero or close to zero data was observed, and in order to fix this defect, using the opinion of experts and according to the withdrawal/receipt values on the same days of the week/month as well as the day before and after, the appropriate value was replaced. It is worth mentioning that due to the electronic registration of transactions in the banking core of the bank, the data is highly accurate and reliable. In the continuation of the work, in order to predict and model properly and to gain confidence in the results, we will divide the data into two parts of training and testing, which ratio in the current research is 80% (training) and 20% (testing).

4.1.1 Identification and management of outlier data

Considering that in the statistical methods of forecasting time series, sample distribution and identification and removal of outliers are effective in learning and predicting the model, hence checking the distribution of problem data in terms of whether they are normal or non-normal. was done and for this purpose the Kolmogorov-Smirnov test was used, in which the null hypothesis is that the data is normal, and if the test statistic is smaller than the critical value, the null hypothesis will be rejected. In the research, the null hypothesis was rejected and it was found that the data is non-normal. Therefore, the method of standard deviation of non-normal distribution and the interquartile

range tool (IQR) were used to identify and replace outliers, in such a way that numbers smaller than the first quartile minus one and a half times the IQR and larger than the fourth quartile plus one and a half times IQR was adjusted and the lowest acceptable value in the interval for smaller numbers and the highest acceptable value in the interval for numbers larger than the highest value in the training data of the seasonal ARIMA method were considered at the time of the learning operation.

4.1.2 Data stationarity and trend check

Augmented Dickey-Fuller (ADF) test was used to check the stationarity of withdrawal/receipt data of each branch. In the mentioned test, the test statistic after calculation was compared with a significance level of 5% (95% confidence level) and the fact that the test statistic is smaller than the significance level of 5% indicates that the data is stationary, which for the 4 time series investigated in this research, Data stationarity was proved. The mathematical relationship of the generalized Dickey-Fuller test is as follows:

$$\Delta y_t = \alpha + \beta t + \gamma y_{t-1} + \delta_1 y_{t-1} + \dots + \delta_{p-1} \Delta y_{t-p+1} + \varepsilon_t \quad (4.1)$$

where alpha is a constant value and beta is a coefficient in time, and P is the delay order of the autoregression process [8]. Also, for a more detailed analysis of cash receipt/withdrawal data, seasonal analysis charts and autocorrelation and partial autocorrelation charts (ACF, PACF) were used, and weekly, monthly and yearly seasonality of the data was also observed in these charts.

4.1.3 Feature selection

In addition to the target data, which is the deposit and withdrawal of cash, we need to define a feature using calendar data to better understand the trend of the target data in the time series. In order to achieve this, the necessary guidance was obtained from the experts of this process and the most important influencing factors, occasions and events and the position of the day of the week, month and season were identified, which the repeatable trends of the graphs of receiving and withdrawing cash from the branches confirm this. are imperative Therefore, in the feature definition section, date and time data were used along with tagging the days with 3 tags: 1. holiday, 2. normal, 3. salary and Eid for the days of the year, and the holidays are Fridays and national holidays and Religions that do not have the aspect of Eid are referred to. Normal days are the days of the year that are not holidays and do not fall on the first and last days of the month and also do not include the occasion of Eid. Eid was defined as the last ten days of the year due to the proximity to Nowruz and other Eid occasions throughout the year.

4.1.4 Data normalization and transformation

The data used in long short term memory method (LSTM) consists of target and auxiliary data, in order to obtain acceptable results, the data must be scaled to an acceptable range, and to do this, the min-max scaler method is used. The value was used and the data was placed between 0 and 1. The relevant mathematical relationship is as follows:

$$\hat{x}_i = \frac{x_i - \min(x)}{\max(x) - \min(x)}. \quad (4.2)$$

Also, due to the class nature of the labels applied to the type of days, we should convert the data into binary data using a dummy variable to avoid the effect of order, which was done by using the one hot encoder coding method and with Converting a column of the day type into three columns corresponding to each of the tags, if there is data in the corresponding class, the number one and otherwise the number zero is assigned to it. Also, for better use of the time characteristics of the data related to the number The day of the month and the number of the season in the year are also used as features, and to avoid the influence of their rotation classification procedure, they are coded using the method of cyclic features and converting each number related to the number of the month and season into two sine features - Cosine was used and the way this function works is that it assigns two numbers between negative one and one to each number of rotational time characteristics and based on how these numbers are placed on the circular chart, one of which is It is related to the sine equivalent and the other is its cosine equivalent so that the month/season number does not affect its relationship with the target data. [17] A sample of auxiliary data after conversion to binary data is shown in Table 1.

The prerequisites for using data in long short-term memory method (LSTM) is to convert time series data that is a column of data connected to time into three-part data used in supervised learning in neural network methods. To

Table 1: Examples of auxiliary data used as features

M-date	Lable-day-1	Lable-day-2	Lable-day-3	month-sin	month-cos	season-sin	season-cos
22/7/2016	1	0	0	0.75	0.07	0.5	0
23/7/2016	0	1	0	0.75	0.07	0.5	0

do that, they divide the time series data into time steps and use the time step data to predict the data after the step is completed [26]. In the current research, 30 days are used to predict the next day, which actually means using thirty days of data, which is equivalent to one month, to predict the next day's data, and after doing this step, The data is ready to be used in the model.

4.2 Seasonal ARIMA method with external factors

This method is one of the statistical methods based on the integrated autocorrelated moving average method (ARIMA) and taking into account the seasonality and influence of data from certain time intervals as well as the influence of external variables, whose full title is: Seasonal Auto-Regressive Integrated Moving Average with exogenous factors. It is worth mentioning that this method is used to predict data that are stationary, and if the data is not stationary, first and second order differentiation is used to stabilize the data and then modeling and forecasting is done. The seasonal ARIMA model is displayed as: SARIMA(p,d,q)x(P,D,Q,s) whose parameters are as follows: P, p: represent the numbers of the autocorrelation term, where the parameter P represents the seasonal autocorrelation. D, d: It represents the difference required to stabilize the time series, where parameter D represents the order of seasonal differentiation. Q, q: represent the numbers of the moving average term, where Q represents the seasonal moving average. S: represents the length of the seasonal data period [25].

4.3 Long-short term memory method

The long-short term memory neural network is a developed recurrent neural network that is classified as deep learning methods and due to its ability to store sequence data long-term and cover the weakness of gradient vanishing /explosion in early deep recurrent networks, it is used Attention and use has been placed. [10] LSTM network has tools called gates. These ports control the flow of information and determine what data in the sequence is important and should be retained and what data should be discarded; In this way, the network passes the important information along the sequence chain to get the desired output. An example of an LSTM cell is shown in Figure 2.

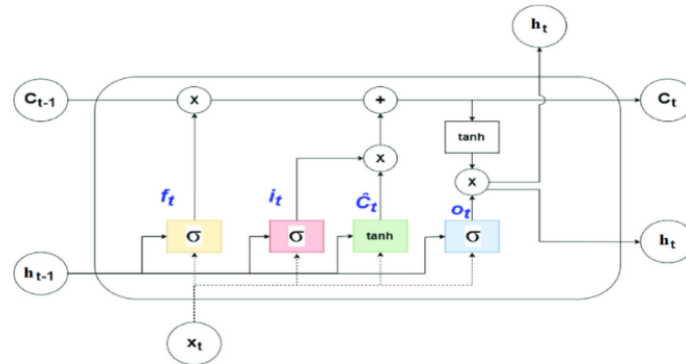

Figure 2: LSTM network cell schematic

where in:

x_t : input value,

$h_{(t-1)}$: output value of previous cell (time point t-1),

h_t : output value of cell,

$c_{(t-1)}$: state of the cell at time point t-1,

c_t : The state of the cell at time point t,

i_t : input port,

f_t : forget port,

c_t : cell state,
 o_t : output port [10].

4.4 Evaluation criteria and comparison of results

In order to evaluate the performance of the models developed in the previous section, three evaluation indicators, the mean percentage of absolute error (MAPE), the root mean square error (RMSE) and the accuracy measure of the coefficient of determination (R^2) were used, whose mathematical relationship is as follows:

$$RMSE = \sqrt{\frac{\sum_1^n (y_{real(i)} - y_{pred(i)})^2}{n}} \quad (4.3)$$

$$MAPE = \frac{1}{n} \sum_1^n \left| \frac{(y_{real(i)} - y_{pred(i)})}{y_{real(i)}} \right| \quad (4.4)$$

$$R^2 = 1 - \frac{\sum_1^n (y_{real(i)} - y_{pred(i)})^2}{\sum_1^n (\bar{y}_{real(i)} - y_{real(i)})^2} \quad (4.5)$$

The first two indicators indicate the quantitative and percentage prediction error with a lower value and the third index indicates the accuracy in forecasting with a higher value and in the range of zero to one [24].

5 Optimizing costs and social responsibilities

Organizations and commercial businesses in all parts of the world must be profitable and to achieve this, they need to minimize costs and maximize revenues. With the maturity of organizations and paying attention to sustainability issues as well as the legal requirements of governments, in addition to the financial dimension which is of particular importance for businesses, optimization of social responsibilities is also proposed as a goal opposite to cost reduction. The ability to optimize it along with cost minimization is possible in a two-objective planning, which will be explained in detail and how to do it in this section.

5.1 Costs and limitations of providing cash services in banks

The main and specific costs of providing cash services to customers in the investigated bank include transportation and money transfer costs, inventory and maintenance costs, which include the unprofitability of using money for the bank, and costs related to the insurance of cash in the fund. The branches and treasury of the bank, which we will discuss briefly in detail below:

5.1.1 Costs and limitations of cash transportation

In order to provide the cash needed by their branches, banks usually provide services by the bank itself or by providing services through financing companies. It should be ensured that the required personnel are hired based on the estimated volume of cash transfer operations, and the greater the amount of cash transfer operations, the more personnel are needed to cover remittance missions. Another transportation cost is related to the costs of the money transfer vehicle, which apart from the fixed costs, brings costs to the bank for each money transfer operation. In order to provide cash services to branches, bank treasury has limitations such as the amount of cash that can be kept in the treasury and can be transferred in each mission, which is limited both from the point of view of physical space and from the point of view of the limit of insured funds.

5.1.2 Costs and limitations of cash holdings and inventory

Banks, due to the deposit resources they attract from customers, must keep a part of it as a cash reserve to meet the cash needs of their customers as well as other customers of the banking network in their branches and treasuries. A deposit that is kept in cash leads to a decrease in the power of providing facilities to customers or lending to other banks in the interbank network, which is done based on the rate approved by the central bank, and this lack of benefit from the main costs. Providing cash services to customers. Another cost is related to the insurance of cash funds kept in the treasury and bank branches, which is calculated as a percentage of the funds and paid to the insurance companies, and the amount of money that can be kept in the treasury of the branches and banks has a limit, and the excess of It is not covered by insurance.

5.2 Social responsibilities of banks in cash logistics

Banks and other public and private for-profit organizations, with the aim of promoting brand reputation among customers or legal requirements, have an approach to social responsibilities in fulfilling their missions, and as mentioned in the background of the research, this issue in recent years It has had a more effective role in formulating strategies and carrying out operational plans of organizations, and in the researches conducted in this regard, the positive role of social responsibilities in improving the performance of banks in different countries has been examined and confirmed [23]. Also, in 2010, the World Standard Organization presented the ISO26000 standard in order to integrate actions that can be taken in this field [13]. This standard is a general guide for all organizations and companies in different dimensions and industries for how to act on social responsibilities and has seven core subjects as follows: Corporate governance, human rights, labor practices, environment, fair operating practices, consumer issues and community involvement and development

Depending on the type of mission and business, as well as the dimensions of the activity, each organization can deal with some or all of these subjects. In the investigated bank, using the opinions of banking and social responsibilities experts, among the 7 core subjects, 4 subjects related to the bank's cash transfer process to fulfill social responsibilities were identified, which were: labor practices, community involvement and development, environment and Customer issues, which actually pay attention to the expectations of the main stakeholders of the bank, which are the society, customers and employees. The main topics along with related core subjects, the social effects of their compliance and their measurement criteria are presented in Table 2.

Table 2: Social effects and criteria for measuring compliance with the bank's social responsibilities in cash logistics

Core subjects	issues in sub-clause	social impact	Measurement criteria
Labor practices	Conditions of work and social protection	fairness of work condition	Number of funding missions
Labor practices	Health and safety at work	safety of workers	Number of working days lost due to work hazards
Community involvement and development	Employment creation and skills development	fairness of work condition	The number of person-hours of employment created
The environment	Prevention of pollution	environmental quality	Carbon dioxide pollution due to cash transfer operation
Consumer issues	Consumer service, support and complaint and dispute resolution	service level and stock out	Number of cash shortages occurred

It is worth mentioning that the supply chain of cash in the banking network is a closed loop supply chain, and by collecting unusable and inappropriate money and returning it to the treasury of the Central Bank, another action is taken in the field of environment, which is Paying attention to the small amount of inappropriate money at the level of branches and regional treasuries, it has been ignored in this research.

5.3 Mathematical programming model

As presented in the third section, cash services are provided to customers in each branch by its counters and ATMs, and planning can be done to optimize the cash balance for each branch. In this section, we introduce and briefly describe its mathematical model:

5.3.1 Index

t: day number in the time horizon

5.3.2 parameters

The parameters of the model are as follows:

h: time horizon

ρ : variable cost for moving each currency unit by the cash transfer team

ϕ : fixed cost for the cash transfer operation to a branch by the cash transfer team

L: The minimum amount of cash that the branch's cash balance should not be less than

R: The maximum amount of cash that the branch's cash balance should not exceed

ε : the percentage of the initial possible demand for cash (before the visit of the cash transfer team) from the total demand for cash that day

d_D^t : the amount of cash expected for customers' cash deposits on day t

d_W^t : the amount of cash expected for customers' cash withdrawals on day t

i^t : the unprofitable rate of cash for the bank on day t

M: Maximum movable cash for a branch in a time horizon

A: The minimum amount of cash needed to carry out cash transfer operations

θ_J : the weight of the measure of job positions created in cash transfer missions

θ_r : the weight of the measure of the risk of creating accidents in cash transfer missions

θ_l : the weight of the measure of the number of working days lost due to money supply missions

θ_P : the weight of the measure of average air pollution created in cash transfer missions

μ : Average risk factor of creating accidents in funding missions

δ : Average number of working days lost due to incidents in funding missions

ω : Average person-hours of jobs created in each funding mission

β : Average air pollution caused by each funding mission

5.3.3 Variables

The variables of the model are as follows:

C^t : cash available in the bank's branch cash desk and ATMs on day t

I^t : the amount of money inflow to the branch by the regional treasury on day t

O^t : amount of money outgoing from the branch by the regional treasury on day t

U^t : net amount of money input/output of the branch in exchange with the treasury on day t

Z^t : binary variable and equal to one if the variable U is non-zero on day t and equal to zero if the variable U is zero on day t

5.3.4 Objective function and constraints

$$\min(Z_1) = \sum_{t=1}^{H-1} (i^t C^t) + \sum_{t=1}^{H-1} (\phi Z^t + \rho U^t) \quad (5.1)$$

$$\max(Z_2) = \theta_j \left(\sum_{t=1}^{H-1} Z^t \omega \right) - \theta_r \left(\sum_{t=1}^{H-1} Z^t \mu \right) - \theta_p \left(\sum_{t=1}^{H-1} Z^t \beta \right) - \theta_l \left(\sum_{t=1}^{H-1} Z^t \delta \right) \quad (5.2)$$

s.t :

$$\sum_{t=1}^{H-1} C^t \leq R \quad \forall t \in [0, H-1] \quad (5.3)$$

$$U^t \geq Z^t A \quad \forall t \in [0, H-1] \quad (5.4)$$

$$C^t = C^{t-1} + I^t - O^t - d_w^t + d_d^t \quad \forall t \in [0, H-1] \quad (5.5)$$

$$I^t + O^t \leq Z^t M \quad \forall t \in [0, H-1] \quad (5.6)$$

$$C^t \geq L \quad \forall t \in [0, H-1] \quad (5.7)$$

$$C^t \geq \varepsilon d_w^t \quad \forall t \in [0, H-1] \quad (5.8)$$

$$U^t = |I^t - O^t| \quad \forall t \in [0, H-1] \quad (5.9)$$

$$O^t = I^t \quad \forall t \in [0, H-1] \quad (5.10)$$

$$C^t \leq K \quad \forall t \in [0, H-1] \quad (5.11)$$

$$O^t \leq C^t + d_D^t \quad \forall t \in [0, H-1] \quad (5.12)$$

$$O^t, I^t, C^t, U^t \geq 0 \forall t \in [0, H-1] \quad (5.13)$$

Descriptions of objective functions and constraints are as follows: The first objective function in relation 5.1 is to minimize the total costs, including the cost of maintaining and not using money and the cost of moving cash, and the

second objective function in relation 5.2 is to optimize the social responsibilities of the bank, including man-hours, job creation, in cash transfer missions, the incidents that occurred in cash transfer missions, the number of working days lost by employees due to work accidents, and the amount of carbon dioxide pollution in cash transfer missions. It is worth mentioning that according to the bank's approach to reduce the number of cash shortages to zero, issues related to customers have been included in the model. The limit of relation 5.3 indicates that the total money of the branch fund in the time horizon should not exceed the allowed limit (parameter R). In the limit of relation 5.4, the net amount of money movement between the branch and the treasury (U) must be equal to zero, or if it is non-zero, it must be greater than the minimum amount of the money transfer order (parameter A). In the limit of relation 5.5, the equation of the balance of the fund on each day is stated, whose amount on each day (C^t) is equal to the amount of the balance of the branch fund on the previous day (C^{t-1}) plus the amount of money received by the treasury. (I^t) and cash deposits (d_D^t) minus the amount of money issued by the treasury (O^t) and cash withdrawals (d_W^t). In the limit of relation 5.6, the total amount of money movement between the branch and the regional treasury every day must either be equal to zero (if the variable Z is zero) or it must be less than the allowed daily amount (parameter M). The limit of relation 5.7 guarantees the availability of the minimum amount of cash determined in the branch every day, and the balance amount of the branch fund every day must be greater than the minimum allowed amount of the fund (parameter L). The constraint of relationship 5.8 takes into account the need to meet the needs of receiving cash before the cash transfer team arrives every day and considers the minimum amount of cash needed for this based on the estimated amount of withdrawal for each branch per day. The limit of the relationship 5.9 shows the relationship between I, O, U variables and expresses the net amount of money transferred between the regional treasury and the branch every day. The limitation of the relation 5.10 shows the impossibility of conducting money supply operations on holidays, and because of this, the value of the variables I, O and as a result the variable U is equal to zero on these days. The limit of relation 5.11 states the ceiling of the allowed money keeping in the branch every day, which is based on insurance considerations. The limit of relation 5.12 specifies the maximum amount of money that can be transferred from the branch to the treasury per day. The limit of relation 5.13 expresses the acceptable limits of the variables of the problem.

5.4 LP-metric method

LP-metric method is one of the multi-criteria decision-making methods (MCDM) that is used to solve multi-objective problems (MODM). In this method, we minimize the total power of the relative deviations of the objectives from their optimal value and we look for the objective function by using which all the functions approach their optimal value. In this method, measuring the weighted distance L_p of each solution x from the ideal solution $f_j(x^{\max(j)})$ can be minimized in the form of the following relationship:

$$L_p = \sum_1^k W_j (f_j(x^{\max(j)}) - f_j(x))^p)^{\frac{1}{p}} \quad (5.14)$$

where w_j is a non-negative weight that is assigned to each objective function by the decision maker, and p indicates the importance of the deviation of each objective function from its ideal value for the decision maker, and its value is...And the specifier is in the direction of emphasis on existing deviations, and the higher its value, the greater the emphasis will be on the biggest deviations. [19] Equation 5.14 is used when the scale of the objective functions is the same, and if the scales are not the same, the following formula can be used.

$$L_p = \left\{ \sum_1^k W_j \left[\frac{f_j x^{\max(j)} - f_j(x)}{f_j x^{\max(j)}} \right]^p \right\}^{\frac{1}{p}} \quad (5.15)$$

In this research, due to the non-uniformity of scales, relation 5.15 is used.

6 Numerical results

The results section consists of two parts: forecasting results and optimization results, and in section 6.1, the forecasting results of time series of cash receipts and withdrawals using SARIMAX and LSTM methods and comparing and choosing the best method for forward forecasting It is presented for one week, which is done in Python software and using statistical libraries and neural networks. In section6.2, the results of the two-objective optimization function

of cost minimization and social responsibility maximization are presented using the weighted comprehensive criterion method, which determines the value of the problem variables for both branches during the considered time horizon. And this part was done in the GAMS software using the CPLEX solver and the LP-metric method.

6.1 The results of the prediction section

As it was said, considering that in the present study, the prediction of both cash flow in and out of a branch with an ATM/RATM machine is considered and considering the number of two sample branches under research, with four time series where two of them is related to sample branch one and the other two are related to sample branch two. We are facing that one of the two time series related to each branch is related to cash withdrawal and the other is cash deposit. After performing the data pre-processing steps and initial modeling with both SARIMAX and LSTM methods, we need to select the appropriate parameters to obtain better prediction results, which was done using the limited network search method on hyper-parameters and after Achieving the optimal combination of hyper-parameters, the final models were implemented, and the results of the test data prediction are shown in Figure3.

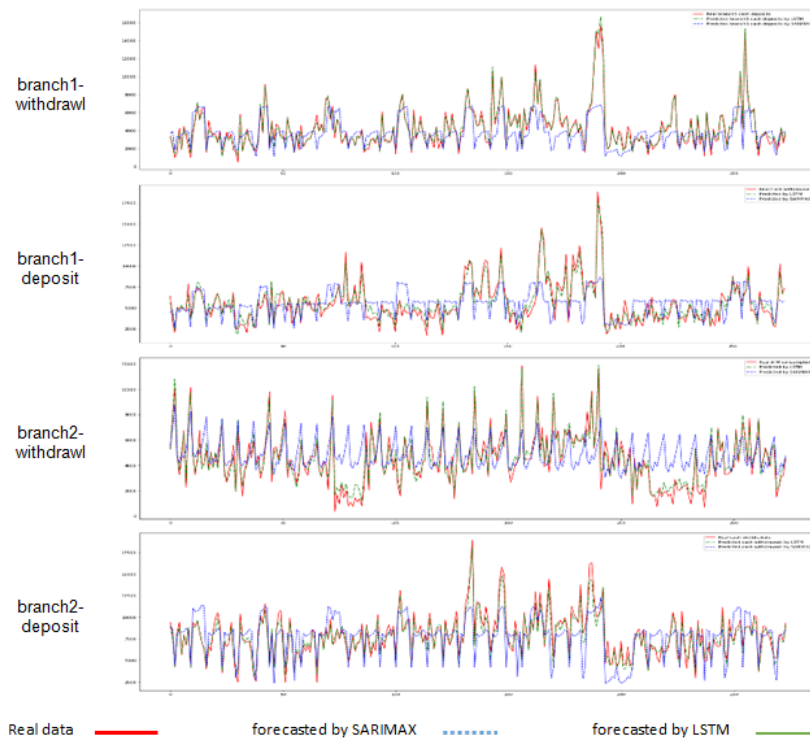

Figure 3: Comparison of the forecast results of cash withdrawal and receipt of sample branches

As seen in Figure 3, the results of the LSTM method are closer to the original data and are more accurate than the prediction results of the SARIMAX statistical method. But in order to make the difference in accuracy and measurement error more tangible, R^2 , RMSE and MAPE evaluation criteria were used, and the results are as described in Table 3.

Table 3: Comparison of cash forecasting results with criteria for evaluating accuracy and forecasting error

Branch	withdrawal/ deposit	SARIMAX			LSTM		
		RMSE	MAPE	R^2	RMSE	MAPE	R^2
1	withdrawal	2154.96	30.92	0.22	719.1	12.34	0.91
	deposit	1925.71	32.22	0.33	373.2	8.69	0.97
2	withdrawal	1971.73	55.58	0.17	618.53	15.99	0.92
	deposit	2156.16	22.31	0.31	735.62	8.93	0.92
average		2052.14	35.25	0.2575	611.61	11.48	0.93

Based on the obtained results, the superiority of the LSTM method is quite noticeable and the measurement accuracy is above 0.9 and the average error percentage is less than 12%, confirming this claim. Also, the difference in the error of the amount of cash predicted in the RMSE criterion is also very large between the two methods, according to the results, the LSTM method is chosen as the best method and used to predict the amount of future cash inflow/outflow or so-called forecasting. It is used in front of branches. It should be noted that obtaining the results of predicting the cash of bank branches and ATMs in similar studies has rarely been achieved with an accuracy higher than 0.9 and an approximate error of 10%, which indicates the selection of appropriate features and modeling of the research problem. In order to predict the future amount of cash inflow/outflow of the branches, all available 5-year withdrawal/receipt data were used as training data and a forward prediction was made for a one-week horizon, the results of which are as described in Table 4.

Table 4: Forward forecast of cash withdrawal/receipt of sample branches

day of the week	Branch1		Branch2	
	withdrawal	deposit	withdrawal	deposit
Saturday	5065.1	6593.16	4929.3	3245.86
Sunday	4867.9	4379.61	3660.6	3424.02
Monday	2250.4	4682.23	4001.9	2224.84
Tuesday	1934.9	7540.81	6651.4	2902.45
Wednesday	2940.3	8043.86	8985.2	4400.78
Thursday	3358.6	7300.41	7252.0	2995.27
Friday	4192.3	9510.12	6892.0	3821.45

* The figures are in millions of Rials.

Considering the very short period of the forecast made in comparison with the training data and the use of external factors as a feature, it is expected that the forecast made will have high accuracy and even higher than the prediction of the test data. To check the correctness of this hypothesis, after performing the optimization step, not facing a deficiency as well as the acceptable distance of the forward prediction made with real data will confirm the accuracy before accepting it, which is presented in section 6.2.

6.2 The results of the optimization section

After achieving the predicted amounts of daily cash withdrawals and receipts for each branch, these numbers are used to optimize the branches' cash balance and by placing the predicted withdrawal and receipt amounts along with other parameters in section 5.3 and solving The model uses the comprehensive criterion method to obtain the best possible solution that has the smallest distance from the ideal solution, and the values of the problem variables for the two branches investigated in the research are as described in Tables 5 and 6.

Table 5: Values of optimization model variables for branch one

Branch1	d_W^t	d_D^t	C^t	I^t	O^t	U^t	Z^t
Saturday	5065.1	6593.16	1528.08	0	0	0	0
Sunday	4867.9	4379.61	1039.78	0	0	0	0
Monday	2250.4	4682.23	3471.66	0	0	0	0
Tuesday	1934.9	7540.81	4077.58	0	5000	5000	1
Wednesday	2940.3	8043.86	4181.16	0	5000	5000	1
Thursday	3358.6	7300.41	1000	0	7122.98	7122.98	1
Friday	4192.3	9510.12	6317.78	0	0	0	0
Z^{cost}	45,163.485		Z^{CSR}	1094.25			

In the explanation of the obtained values, it can be said that during a week, the cash receipt and withdrawal data of each branch specifies the amount of the fund balance, the amount of incoming/outgoing cash and the days when the cash transfer car needs to visit the branch. For a planned week, we need 3 visits for branch one and 4 visits for branch two. Due to the withdrawal of more cash in proportion to its receipt in the second branch, cash is injected into the branch every time the cash transfer car goes to the branch, and this is the opposite in the first branch, and every

Table 6: : Values of optimization model variables for branch two

Branch2	d_W^t	d_D^t	C^t	I^t	O^t	U^t	Z^t
Saturday	4929.3	3245.86	7301.737	8985.13	0	8985.13	1
Sunday	3660.6	3424.02	7065.137	0	0	0	0
Monday	4001.9	2224.84	13288.08	8000	0	8000	1
Tuesday	6651.4	2902.45	20000	10460.83	0	10460.83	1
Wednesday	8985.2	4400.78	15415.61	0	0	0	0
Thursday	7252.0	2995.27	20000	8841.07	0	8841.07	1
Friday	6892.0	3821.45	16929.44	0	0	0	0
Z^{cost}	112,810		Z^{CSR}	1378			

time the cash transfer car goes to the branch, excess cash is received from the branch. and at the level of the regional treasury that supports about fifty branches, optimal management of withdrawals and receipts similar to the planning done for branches is possible. Also, the target function values for the total costs are 45,163 million rials for branch one and 112,810 million rials for branch two, and after the implementation of the proposed one-week operational plan, the two mentioned branches not only did not face a shortage of cash, but also reduced 30% of the total costs of each branch compared to the previous method of payment. Also, the number of visits to the cash transfer car was adjusted in such a way that, while reducing the costs of the cash transfer, the bank’s social responsibilities in cash logistics were optimized.

7 Summary

Prediction and optimization of cash balance of bank branches and ATMs as a two-step process to achieve optimal operational planning of cash logistics has been studied in several researches. But carrying out this two-stage process in an integrated manner, as well as paying attention to the social responsibilities of banks in cash logistics, has been considered in very few researches, which was carried out simultaneously in the present research. On the other hand, the high accuracy of predicting the required cash using external factors and modern neural network methods is one of the main features of this research, during which using 5-year historical data of cash withdrawal/receipt of sample branches and using the method Seasonal ARIMA was used to predict both cash flow inflow and outflow by taking into account external factors and long short-term memory method, and the average absolute percentage of error is lower than 12% in forecasting with long short-term memory (LSTM) method, which proves accuracy. It was done above the forecast. Also, optimizing the cash balance of branches by taking into account the financial goals and social responsibilities based on the ISO 26000 standard is one of the new measures in the cash logistics of banks that was carried out in this research, during which, besides minimizing the costs of money transfer and Maintaining cash, maximizing the level of cash service to customers by responding to their cash requests without the occurrence of shortages, as well as optimizing job creation, reducing air pollution and cash transferring accidents, and as a result, the number of cash transferring missions and the amount of cash The entry and exit to the branches in each mission was determined for a time horizon of seven days, as a result of the implementation of the proposed program, a significant reduction (about 30%) of the costs of providing cash services to meet the needs of customers was achieved, which if applied to all branches of the bank The review should be generalized, it will result in a minimum reduction of 10,000 billion Rials per year for the costs of providing cash services, which will be a very good achievement in the banking industry, along with the optimization of social responsibilities. Future researchers are advised to use the data related to competitors and the size of the local market if possible to obtain better results in cash flow forecasting, as well as the use of new and combined methods in forecasting and comparing its results with the LSTM method. becomes In the optimization section, it is recommended to consider the costs and environmental effects of banknote production, as well as the use of meta-heuristics algorithm methods and comparing the results with multi-criteria decision-making methods.

References

- [1] C. Bilir and A. Doseyen, *Optimization of ATM and branch cash operations using an integrated cash requirement forecasting and cash optimization model*, Bus. Manag. Stud. **6** (2018), no. 1, 237–255.
- [2] Y. Ekinici, N. Serban, and E. Duman, *Optimal ATM replenishment policies under demand uncertainty*, Oper. Res. **21** (2021), 999–1029.

- [3] A. Fallahtafti, M. Aghaaminiha, S. Akbarghanadia, and G.R. Weckman, *Forecasting ATM cash demand before and during the COVID-19 pandemic using an extensive evaluation of statistical and machine learning models*, Sn. Comput. Sci. **3** (2022), no. 164.
- [4] J. García Cabello and F.J. Lobillo, *Sound branch cash management for less: A low-cost forecasting algorithm under uncertain demand*, Omega **70** (2017), 118–134.
- [5] O. Gorodetskaya, Y. Gobareva, and M. Koroteev, *A machine learning pipeline for forecasting time series in the banking sector*, Economies **9** (2021), no. 4.
- [6] S. Gray, *Central bank balances and reserve requirements*, Tech. report, International Monetary Fund, Washington, DC, USA, 2011.
- [7] H. Gurgul and M. Suder, *Modeling of withdrawals from selected ATMs of the “Euronet” network*, Manag. Econ. **13** (2013), 65.
- [8] R.I.D. Harris, *Testing for unit roots using the augmented dickey-fuller test: Some issues relating to the size, power and the lag structure of the test*, Econ. Lett. **38** (1992), no. 4, 381–386.
- [9] D. Heller and Y. Lengwiler, *Payment obligations, reserve requirements, and the demand for central bank balances*, J. Monetary Econ. **50** (2003), no. 2, 419–432.
- [10] S. Hochreiter and J. Schmidhuber, *Long short-term memory*, Neural Comput. **9** (1997), no. 8, 1735–1780.
- [11] C. Jariyavajee, T. Lamjiak, S. Ratanasanya, S. Fairee, K. Puphaiboon, and C. Khompatraporn, *Cash stock strategies during regular and COVID-19 periods for bank branches by deep learning*, PLOS ONE **17** (2022), no. 06, 1–23.
- [12] N. Kiani, G. Tohidi, S. Razavyan, N. Shadnoosh, and M. Sanei, *Improved NARX-ANFIS network structure with genetic algorithm to optimize cash flow of ATM model*, Adv. Math. Finance Appl. **8** (2023), no. 1, 241–254.
- [13] A. Kumar, *Modelling the importance of social responsibility standards (ISO 26000:2010) practices adoption in freight transport industry*, J. Cleaner Prod. **367** (2022), 132861.
- [14] H. Larrain, L.C. Coelho, and A. Cataldo, *A variable MIP neighborhood descent algorithm for managing inventory and distribution of cash in automated teller machines*, Comput. Oper. Res. **85** (2017), 22–31.
- [15] Y. Liu, S. Dong, M. Lu, and J. Wang, *LSTM based reserve prediction for bank outlets*, Tsinghua Sci. Technol. **24** (2019), no. 1, 77–85.
- [16] J. López Lázaro, A. Barbero Jiménez, and A. Takeda, *Improving cash logistics in bank branches by coupling machine learning and robust optimization*, Expert Syst. Appl. **92** (2018), 236–255.
- [17] S. Meisenbacher, M. Turowski, K. Phipps, M. Rätz, D. Müller, V. Hagenmeyer, and R. Mikut, *Review of automated time series forecasting pipelines*, WIREs Data Min. Knowledge Discov. **12** (2022), no. 6, e1475.
- [18] N. Nazari Ganje, A. Mirzapour, and S. Mohammad J, *An integrated location-inventory routing problem for ATMs in banking industry: A green approach*, pp. 27–52, Springer International Publishing, 2020.
- [19] S. Pasandideh, S. Akhavan Niaki, and K. Asadi, *Optimizing a bi-objective multi-product multi-period three echelon supply chain network with warehouse reliability*, Expert Syst. Appl. **42** (2015), no. 5, 2615–2623.
- [20] S. Song, Y. Tian, and D. Zhou, *Reverse logistics network design and simulation for automatic teller machines based on carbon emission and economic benefits: A study of the Anhui Province ATMs Industry*, Sustainability **13** (2021), no. 20.
- [21] A. Suharsono, A. Masyitha, and A. Anuravega, *Time series regression and ARIMAX for forecasting currency flow at Bank Indonesia in Sulawesi region*, AIP Conf. Proc. **1691** (2015), no. 1, 050025.
- [22] R.G. van Anholt, L.C. Coelho, G. Laporte, and I.F.A. Vis, *An inventory-routing problem with pickups and deliveries arising in the replenishment of automated teller machines*, Transport. Sci. **50** (2016), no. 3, 1077–1091.
- [23] T. Van Nguyen, H.T.T. Bui, and C.H.D. Le, *The impacts of corporate social responsibility to corporate financial performance: A case study of Vietnamese commercial banks*, Cogent Econ. Finance **10** (2022), no. 1, 2132642.
- [24] W.W.S. Wei, *Time Series Analysis: Univariate and Multivariate Methods*, Time Series Analysis: Univariate and

Multivariate Methods, Pearson Addison Wesley, 2006.

- [25] H. Weytjens, E. Lohmann, and M. Kleinsteuber, *Cash flow prediction: MLP and LSTM compared to ARIMA and prophet*, *Electron. Commerce Res.* **21** (2019), 371–391.
- [26] Y. Zhu, S. Kumar, S. Rodriguez-Sanchez, and C. Sriskandarajah, *Managing logistics in regional banknote supply chain under security concerns*, *Prod. Oper. Manag.* **24** (2015), no. 12, 1966–1983.